

## Platinum temperature sensor in thin-film technology

L 416

L-series platinum temperature sensors are characterized by long-term stability, excellent precision over a wide temperature range and compatibility. They are used particularly for applications with high consumption volumes, typically in the automotive, white goods, HVAC and energy generation industries as well as in medical and industrial appliances and machinery.

Nominal Resistance R0	Tolerance DIN EN 60751 1996-07	Tolerance DIN EN 60751 2009-05	Order Number Plastic Box
100 Ohm at 0°C	Class A	F 0.15	32 207 583
	Class B	F 0.3	32 207 440

The measuring point for the nominal resistance is defined at 8mm from the end of the sensor body.

<b>Specification</b>	DIN EN 60751	
<b>Temperature range</b>	-50°C to +400°C (continuous operation) Tolerance Class B: -50°C to +400°C Tolerance Class A: -50°C to +300°C	
<b>Temperature coefficient</b>	TCR = 3850 ppm/K	
<b>Leads</b>	AgPd- wire	
<b>Lead lengths (L)</b>	10mm ±1mm	
<b>Long-term stability</b>	Max. R0 drift 0.04% after 1000h at 400°C	
<b>Vibration resistance</b>	at least 40g acceleration at 10 to 2000 Hz, depends on installation	
<b>Shock resistance</b>	at least 100g acceleration with 8ms half sine wave, depends on installation	
<b>Ambient conditions</b>	Use unprotected only in dry environments	
<b>Insulation resistance</b>	> 100 MΩ at 20°C; > 2 MΩ at 400°C	
<b>Self heating</b>	0.4 K/mW at 0°C	
<b>Response time</b>	Water current (v= 0.4m/s):	t <sub>0.5</sub> = 0.07s t <sub>0.9</sub> = 0.25s
	Air flow (v= 2m/s):	t <sub>0.5</sub> = 3.2s t <sub>0.9</sub> = 14.0s
<b>Measuring current</b>	100Ω: 0.3 to 1.0mA (self heating has to be considered)	
<b>Note</b>	Other tolerances, values of resistance and wire lengths are available on request.	

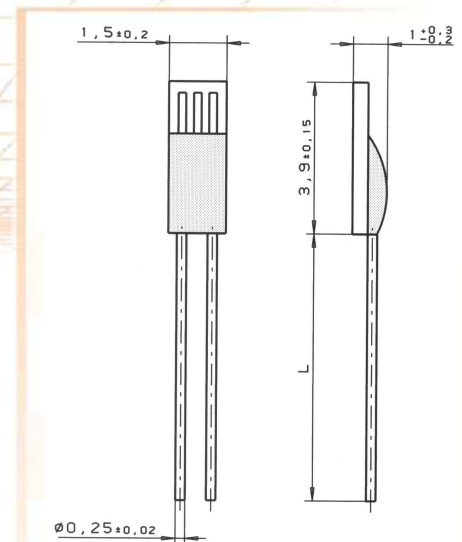

We reserve the right to make alterations and technical data printed. All technical data serves as a guideline and does not guarantee particular properties to any products.

## Heraeus Sensor Technology USA

1901 Route 130  
North Brunswick, NJ 08902  
Phone 732-940-4400 Fax 732-940-4445  
Email info.hst-us@heraeus.com  
www.hst-us.com

Name of document: 30910007 Index A  
Status: 10/2009