

The sensor platform is designed for the mounting of heated sensors. Using heat and temperature resistance, the sensor can, with appropriate control, be kept at a constant temperature or a temperature cycle can be operated. The MSP 769 combines a heater and a temperature sensor in platinum thin film on a ceramic substrate covered with an insulating glass layer. A gold electrode in thick film is deposited on the glass layer, onto which a measuring component can be bonded or applied in thick or thin film technology. The size of the electrode enables the application of the most varied sensitive layers or the mounting of Si-Chips. Bands with lengths of up to 170 millimetres are used as leads. The band design offers a stability that cannot be achieved with a conventional round cross-sectioned wire.

Application

Typical areas of application for the sensor platform are any type of gas sensors and physical sensors such as humidity and air quality sensors.

Technical data

Design	Multi-layer structure with a platinum thin-film structure as temperature sensor and heater on a ceramic substrate, covered with <ul style="list-style-type: none"> - an insulating glass layer (thick film); - thereon a gold electrode in monoplane form (thick film); - two terminal electrodes (other forms of electrodes on request)
Leads	Pt coated Ni wire, diameter 0.20mm
Temperature range	-50°C to +500°C
Nominal resistance, tolerance and characteristic values	<p>Temperature sensor: 1000Ω at 0°C, measuring values and characteristic curve according to DIN EN 60 751, tolerance 0.25%, measuring current 1mA</p> <p>Heater: 25 ± 2.5Ω at 0°C, characteristic curve according to DIN EN 60 751, heater rating max. 3 W in air for unspoil Chip</p>
Stability	Passed 1000 h test at T=450°C (sensor flow I = 1mA)
Note	Other tolerances, values of resistance and wire lengths are available on request.
Status	objective

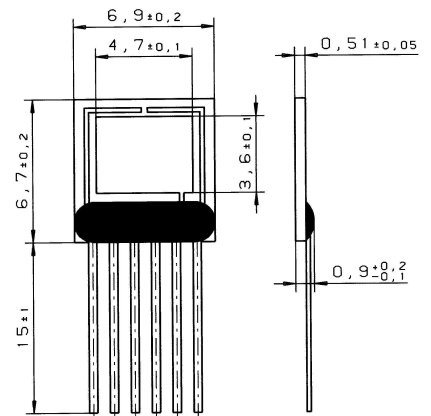
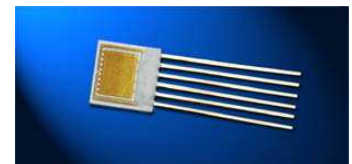

Circuit diagram

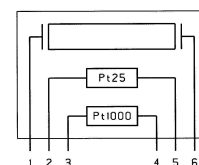

Version 1
separated connection for heater & sensor
Id- Nr 32 208 261



We reserve the right to make alterations and technical data printed. All technical data serves as a guideline and does not guarantee particular properties to any products.

Heraeus Sensor Technology USA

1901 Route 130
North Brunswick, NJ 08902
Phone 732-940-4400 Fax 732-940-4445
Email info.hst-us@heraeus.com
www.hst-us.com