

## Multi-Sensor-Platform

## MSP 332

The sensor platform is designed for the mounting of heated sensors. Using heat resistance the chip can be kept at a constant temperature or a temperature cycle can be operated. The platform integrates a temperature sensor (Pt 1000), a heater and interdigitated electrode structures (IDES) in platinum thin film on a ceramic substrate. Heater and sensor are covered with an insulating glass layer. Sensitive layers can be applied onto the non-passivated electrode structures by using screen process or drop-coating. Via this method the Multi-Sensor-Platform is converted into a gas sensor, humidity sensor etc.

### Application

Typical areas of application for the sensor platform are any type of gas sensors and physical sensors such as humidity and air quality sensors.

### Technical data

#### Design

**Heraeus Sensor Technology** designs the Multi-Sensor Platform with customer-specific sensor layers, heaters and electrode structures in mono- and multi-layer versions. User-defined combinations of these three layers are feasible. Heater and temperature sensors are covered with an insulating glass layer.

#### Layer application

Sensitive layers can be deposited onto the non-passivated electrode structure by using screen process or drop-coating.

#### Connection

Gold-plated Ni leadframe, 0.15 mm thickness  
Au thick film pad for bonding  
max Lead length (L): 50mm

#### IDES

Width / length of conductor: 10  $\mu$ m / 10  $\mu$ m

#### Temperature range

-50°C to +500°C (higher temperatures on demand)

#### Nominal resistance, tolerance and stability

**Temperature sensor:** 1000 Ohm at 0°C,  
tolerance: class B  
according to DIN EN 60 751,  
max. measuring current 0.3 mA

**Heater:**  
17.5  $\Omega$   $\pm$  2,5  $\Omega$ ,

#### Note

Other dimensions, tolerances, values of resistance and leads are available on request.

#### Status

objective

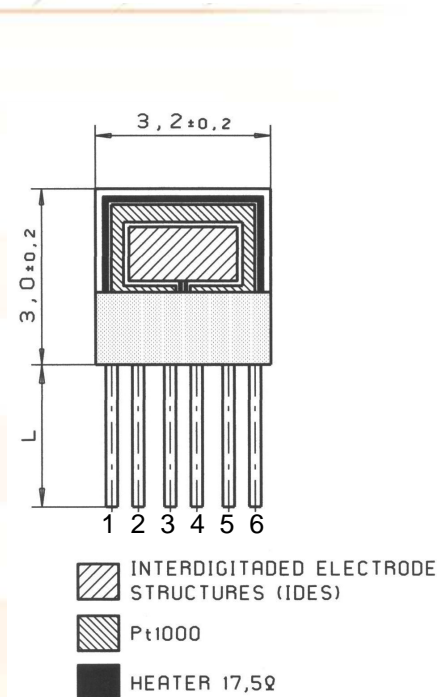

Pins 1 & 6: Heater  
Pins 2 & 5: Pt1000 temperature sensor  
Pins 3 & 4: IDES electrode

We reserve the right to make alterations and technical data printed. All technical data serves as a guideline and does not guarantee particular properties to any products.

## Heraeus Sensor Technology USA

1901 Route 130  
North Brunswick, NJ 08902  
Phone 732-940-4400 Fax 732-940-4445  
Email info.hst-us@heraeus.com  
www.hst-us.com