

Platinum Resistance Temperature Detector

HL 220

HL 220 type platinum sensors are characterised by long-term stability, precision over a broad temperature range and compatibility. The main feature is the small design. They are used in particular for applications with high consumption volumes, e.g. white goods and heating power.

Nominal Resistance R_0	Tolerance up to 750°C	Order No.
1000 Ohm at 0°C	DIN EN 60751, Class 2B	32 208 779
Sensor up to 650°C in tolerance class B on request available.		

The measuring point for the nominal resistance is defined at 6 mm from the end of the sensor body.

Specification	DIN EN 60751
Temperature range	- 70°C up to + 750°C
Temperature coefficient	TCR = 3850 ppm/K
Leads	NiCrPt
Lead lengths (L)	8 mm +- 1mm
Long-term tests	R_0 - Drift after 1000h at 750°C (energized) < 0,24% (Unhoused chip in standard atmosphere.)
Environmental conditions	Unhoused for dry environmental only, above 500°C no reducing atmosphere, free air admission is necessary. Assembly can influence the long term stability!
Vibration resistance	at least 40 g acceleration at 10 to 2000 Hz, depends on installation
Shock resistance	at least 100 g acceleration with 8ms half sine wave, depends on installation
Insulation resistance	> 100 MOhm at 20 °C; > 2 MOhm at 650 °C
Self heating	0.2 K/mW
Response time	Water current ($v = 0.4$ m/s): $t_{0.5} = 0.05$ s; $t_{0.9} = 0.14$ s Air stream ($v = 2$ m/s): $t_{0.5} = 3.0$ s ; $t_{0.9} = 10$ s
Measuring current	0.1 to 1mA (self heating has to be considered)
Packaging	Plastic bag
Note	Other tolerances, values of resistance and wire lengths are available on request.

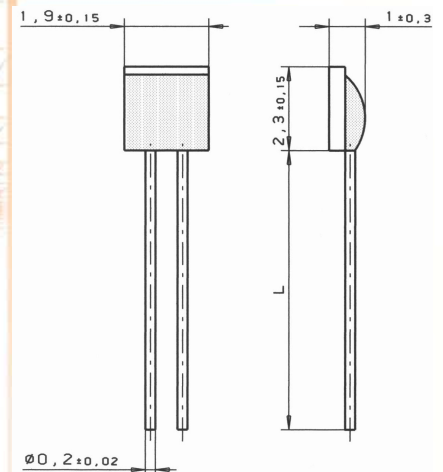

We reserve the right to make alterations and technical data printed. All technical data serves as a guideline and does not guarantee particular properties to any products.

Heraeus Sensor Technology USA

1901 Route 130
North Brunswick, NJ 08902
Phone 732-940-4400 Fax 732-940-4445
Email info.hst-us@heraeus.com
www.hst-us.com