

## Platinum Resistance Temperature Detector

L 220

L series PRTDs are designed for large volume applications where long term stability, interchangeability and accuracy over a large temperature range are vital. Typical applications are Automotive, White goods, HVAC, Energy management, Medical and Industrial equipment.

Nominal Resistance $R_0$	Tolerance	Order No. Plastic bag
100 Ohm at 0°C	DIN EN 60751, class B	32 207 400
	DIN EN 60751, class A	32 207 584
	DIN EN 60751, class 1/3 DIN	32 207 588
	Class 1/10 DIN @ 0 Deg C	32 207 333
	Class 1/5 DIN @ 0 Deg C	32 207 519

The measuring point for the nominal resistance is defined at 8 mm from the end of the sensor body.

<b>Specification</b>	DIN EN 60751 (according to IEC 751)	
<b>Temperature range</b>	-50°C to +400°C (continuous operation) Tolerance class B: - 50 °C to + 400 °C Tolerance class A: - 50 °C to + 300 °C Tolerance class 1/3 DIN: 0 °C to + 150 °C	
<b>Temperature coefficient</b>	TCR = 3850 ppm/K	
<b>Leads</b>	AgPd	
<b>Lead lengths (L)</b>	10 mm +- 1 mm	
<b>Long-term stability</b>	max. $R_0$ -drift 0.04% after 1000 h at 400°C	
<b>Vibration resistance</b>	at least 40 g acceleration at 10 to 2000 Hz, depends on installation	
<b>Shock resistance</b>	at least 100 g acceleration with 8ms half sine wave, depends on installation	
<b>Environmental conditions</b>	unhoused for dry environments only	
<b>Insulation resistance</b>	> 100 M $\Omega$ at 20°C; > 2 M $\Omega$ at 500°C	
<b>Self heating</b>	0.4 K/mW at 0°C	
<b>Response time</b>	water current ( $v = 0.4$ m/s):	$t_{0.5} = 0.06$ s $t_{0.9} = 0.20$ s
	air stream ( $v = 2$ m/s):	$t_{0.5} = 3.0$ s $t_{0.9} = 13.0$ s
<b>Measuring current</b>	0.3 to 1.0 mA (self heating has to be considered)	
<b>Note</b>	Other tolerances, values of resistance and wire lengths are available on request.	

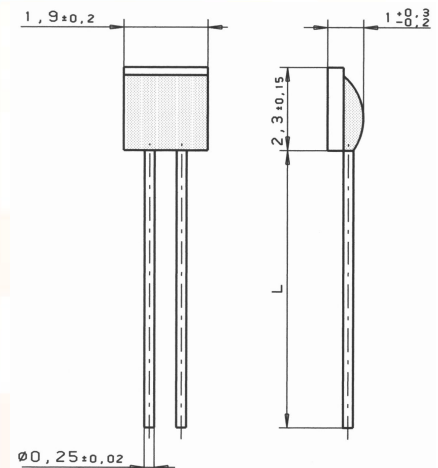

We reserve the right to make alterations and technical data printed. All technical data serves as a guideline and does not guarantee particular properties to any products.

## Heraeus Sensor Technology USA

1901 Route 130  
North Brunswick, NJ 08902  
Phone 732-940-4400 Fax 732-940-4445  
Email info.hst-us@heraeus.com  
www.hst-us.com

Status: 10/2007, HSTUSA 10/09