

Platinum Resistance Temperature Detector

M 213

M series PRTDs are designed for large volume applications where long term stability, interchangeability and accuracy over a large temperature range are vital. Typical applications are Automotive, White goods, HVAC, Energy management, Medical and Industrial equipment.

Nominal Resistance R_0	Tolerance	Order No. Plastic bag
100 Ohm at 0°C	DIN EN 60751, class B	32 207 690
	DIN EN 60751, class A	32 207 691
	DIN EN 60751, class 1/3 DIN	32 207 692
1000 Ohm at 0°C	DIN EN 60751, class B	32 207 695

The measuring point for the nominal resistance is defined at 8 mm from the end of the sensor body.

Specification	DIN EN 60751 (according to IEC 751)	
Temperature range	-70°C to +500°C (continuous operation) (temporary use to 550 °C possible) Tolerance class B: - 70 °C to + 500 °C Tolerance class A: - 50 °C to + 300 °C Tolerance class 1/3 DIN: 0 °C to + 150 °C	
Temperature coefficient	TCR = 3850 ppm/K	
Leads	Pt clad Ni wire Recommended connection technology: Welding, Crimping and Brazing	
Lead lengths (L)	10 mm +/- 1 mm	
Long-term stability	max. R_0 -drift 0.04% after 1000 h at 500°C	
Vibration resistance	at least 40 g acceleration at 10 to 2000 Hz, depends on installation	
Shock resistance	at least 100 g acceleration with 8ms half sine wave, depends on installation	
Environmental conditions	unhoused for dry environments only	
Insulation resistance	> 100 M Ω at 20°C; > 2 M Ω at 500°C	
Self heating	0.6 K/mW at 0°C	
Response time	water current ($v = 0.4$ m/s):	$t_{0.5} = 0.04$ s $t_{0.9} = 0.12$ s
	air stream ($v = 2$ m/s):	$t_{0.5} = 2.2$ s $t_{0.9} = 7.0$ s
Measuring current	100 Ω : 0.3 to 1.0 mA 1000 Ω : 0.1 to 0.3 mA (self heating has to be considered)	
Note	Other tolerances, values of resistance and wire lengths are available on request.	

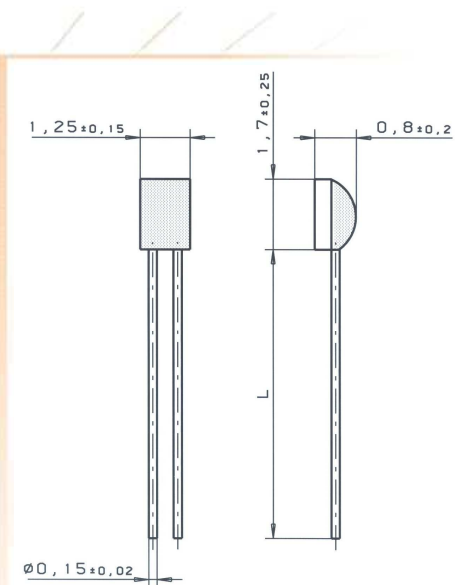

We reserve the right to make alterations and technical data printed. All technical data serves as a guideline and does not guarantee particular properties to any products.

Heraeus Sensor Technology USA

1901 Route 130
North Brunswick, NJ 08902
Phone 732-940-4400 Fax 732-940-4445
Email info.hst-us@heraeus.com
www.hst-us.com

name of document: 30910012 Index B
Status: 11/2008, HSTUSA 10/09